

OVERALL DIMENSIONS / METALLIC VERSIONS

- SCP TVP00RW ☺ JD38999/20W ☺
 - SCP TVPS00RF JD38999/20F
 - SCP TVPS00RB
 - SCP TVPS00RK JD38999/20K
 - SCP TVPS00RS JD38999/20S
- Square flange receptacle

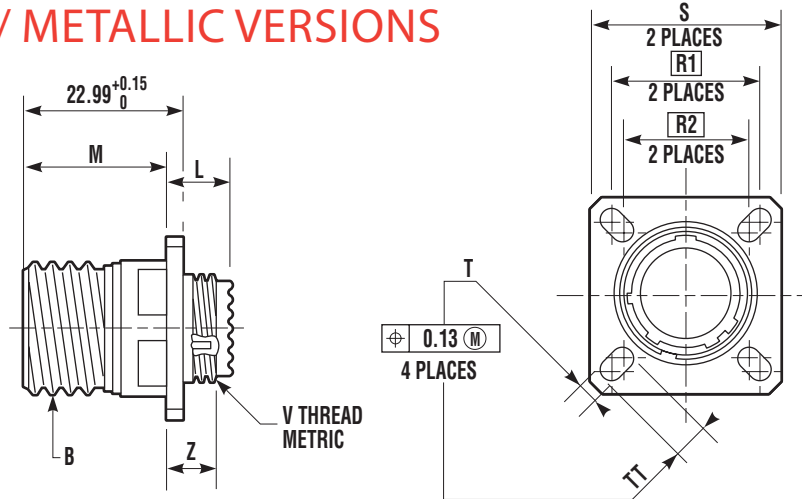

Shell size		B thread Class 2A 0.1P-0.3L-TS (inches)	L Max (mm)	M +0.00 -0.13 (mm)	R1 (mm)	R2 (mm)	S ±0.25 (mm)	T +0.20 -0.13 (mm)	Z1 Max (mm)	TT +0.20 -0.13 (mm)	V thread metric
MIL-DTL-38999 Series III	SCP TV										
A	9	.6250	11.91	20.83	18.26	15.09	23.83	3.25	3.89	5.49	M12x1-6g
B	11	.7500	11.91	20.83	20.62	18.26	26.19	3.25	3.89	4.93	M15x1-6g
C	13	.8750	11.91	20.83	23.01	20.62	28.58	3.25	3.89	4.93	M18x1-6g
D	15	1.0000	11.91	20.83	24.61	23.01	30.96	3.25	3.89	4.39	M22x1-6g
E	17	1.1875	11.91	20.83	26.97	24.61	33.32	3.25	3.89	4.93	M25x1-6g
F	19	1.2500	11.91	20.83	29.36	26.97	36.53	3.25	3.89	4.93	M28x1-6g
G	21	1.3750	12.70	20.07	31.75	29.36	39.67	3.25	4.65	4.93	M31x1-6g
H	23	1.5000	12.70	20.07	34.93	31.75	42.88	3.91	4.65	6.15	M34x1-6g
J	25	1.6250	12.70	20.07	38.10	34.93	46.02	3.91	4.65	6.15	M37x1-6g

For panel drilling, please refer to page 23

For PCB contacts stickout, please refer to page 22

Maximum panel thickness for rear panel mounting:
 5,18mm from size 21 to 25
 5,94mm from size 9 to 19

- SCP TV07RW ☺ JD38999/24W ☺
 - SCP TVS07RF JD38999/24F
 - SCP TVS07RB
 - SCP TVS07RK JD38999/24K
 - SCP TVS07RS JD38999/24S
- Jam nut receptacle

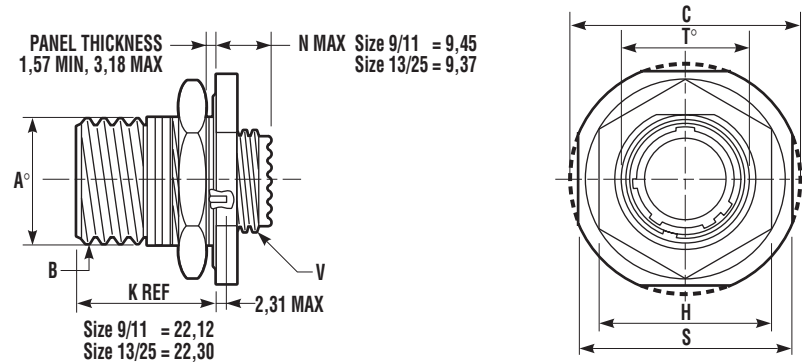

Shell size		B thread Class 2A 0.1P-0.3L-TS (inches)	A +0.00 -0.25 (mm)	C Max (mm)	H Hex +0.43 -0.41 (mm)	S +0.28 -0.25 (mm)	T +0.25 -0 (mm)	V thread metric	Hex nut max torque N.m
MIL-DTL-38999 Series III	SCP TV								
A	9	.6250	16.99	30.45	22.23	26.97	17.70	M12x1-6g	4.1
B	11	.7500	19.53	35.20	25.40	31.75	20.88	M15x1-6g	5.3
C	13	.8750	24.26	38.38	30.17	34.93	25.58	M18x1-6g	6.9
D	15	1.0000	27.53	41.55	33.32	38.10	28.80	M22x1-6g	8.6
E	17	1.1875	30.68	44.73	36.52	41.28	31.98	M25x1-6g	9.8
F	19	1.2500	33.86	49.50	39.67	46.02	35.15	M28x1-6g	10.9
G	21	1.3750	37.06	52.65	42.87	49.23	38.28	M31x1-6g	12.7
H	23	1.5000	40.00	55.85	46.02	52.37	41.50	M34x1-6g	13.8
J	25	1.6250	43.41	59.00	50.80	55.58	44.68	M37x1-6g	15

For panel drilling, please refer to page 23

For PCB contacts stickout, please refer to page 22